

## AR74A - GPS Disciplined Rubidium Clock

### Key Features

- ❖ Frequency Accuracy :  $2E-12$
- ❖ 1PPS Accuracy: Typ. 20ns (RMS)
- ❖ NTP Server
- ❖ Excellent Holdover:  $<1\mu\text{s/day}$ ,  $5E-11/\text{month}$
- ❖ Outputs: 10MHz, 1PPS (TTL & RS-422), TOD (Have Quick)
- ❖ Input: GPS antenna, 1PPS, TOD (Have Quick)
- ❖ Operating Temperature range:  $-5^{\circ}\text{C}$  to  $+50^{\circ}\text{C}$  (wide temp range opt.)
- ❖ Control and monitoring: RS-232 (input & output), RS-422 (output).
- ❖ Ephemeris, Almanac & Ionosphere Data
- ❖ AC Power 110/220v (28VDC Opt.)
- ❖ Graphic User Interface (GUI) Software for PC (Opt.)



### Description

The **AR74A** unit is GPS-Disciplined Rubidium clock which offers an excellent stability and accuracy. The unit includes a Rubidium which is phase-locked to 1PPS from GPS or other external input. All outputs are derived from the Rubidium signal maintaining excellent accurate time and frequency even when GPS reception is unavailable ( $1\mu\text{s/day}$ ). The unit offer time accuracy of  $\leq 20\text{ns}$  RMS and Frequency accuracy better than  $2E-12$ .

The **AR74A** provides 10MHz sine output and multiple timing outputs such as 1PPS (TTL, RS422, ICD-GPS-060) and TOD (NTP, Have Quick - ICD-GPS-060).

The unit has also TOD (Have Quick - ICD-GPS-060) and 1PPS inputs in order to synchronize the unit from external clock reference when GPS reception is unavailable.

### Applications

- ❖ Communication
  - ❖ Telemetry test fields
  - ❖ Field calibration
- Any other applications which requires accurate source of frequency & time

## PECIFICATIONS

All specs are at room temperature, quiescent conditions, sea level ambient unless otherwise specified.

Input & Outputs	
<b>Outputs</b>	1 x 10MHz, Sine wave (8±3) dBm, BNC 2 X 1PPS TTL/50Ω (1 x BNC, 1 x D-TYPE) 5 x 1PPS ICD-GPS-060/ 50Ω, D-TYPE 4 x 1PPS RS-422, D-TYPE AUX: 1PPS TTL/50Ω or other signal (opt.), BNC 5 X TOD ICD-GPS-060 / 100KΩ, D-TYPE
<b>Input</b>	TOD ICD-GPS-060 TTL/100K Ω, BNC GPS Antenna (TNC) External 1 PPS ICD-GPS-060/ 50Ω or TTL/50Ω, BNC
<b>Communication</b>	CLI RS232 (input/output) for control and monitoring: setting time/date, delay correction for 1PPS 10ns steps, mode of operation; disciplining to GPS/Ext 1PPS, holdover, UTC time, GPS Time, Local Time, Day Light Saving etc....(see CLI document for more information). Baud rate: 19,200, Control: 1, N, 8 CLI RS422 (the Input (RXD) can not be connected simultaneously with the RS232). LAN – NTP GUI for PC is available as an option :Time, Date, Position, Status, BIT (Built in test) etc.

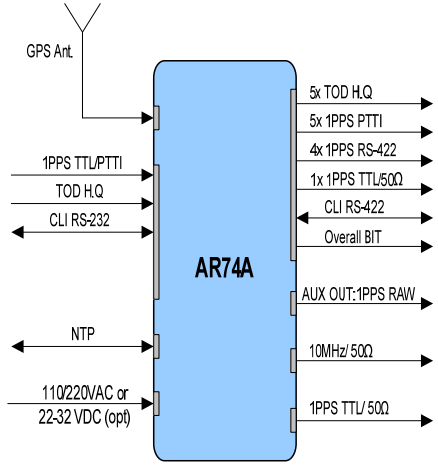

Performance - Disciplined to GPS or to Ext. 1PPS				
<b>Time (1PPS)</b>	<b>Accuracy</b>	≤20ns RMS @ 25°C (Typical)		
	<b>Long Term Stability</b>	< 2E-12 (24 hour average, const temp.)		
	<b>Short Term Stability (ADEV)</b>	≤ 4E-11 @ 1s		
	<b>Temperature Stability</b>	±3E-10 over -5°C to +50°C		
<b>Frequency (10MHz)</b>	<b>Phase Noise</b>	Frequency	Standard (spec)	Standard (typical)
		10Hz	≤-100dBc/Hz	≤-101dBc/Hz
		100Hz	≤-134dBc/Hz	≤-137dBc/Hz
		1KHz	≤-143dBc/Hz	≤-144dBc/Hz
	10KHz	≤-145dBc/Hz	≤-149dBc/Hz	
	<b>Harmonics</b>	≤-45 dBc		
	<b>Spurious</b>	<-75 dBc @ ±100KHz from carrier		
	<b>Warm-up</b>	Rb Lock < 4 min 5E-10 within < 7 min 5E-11 within < 60 min, 1E-11 within < 4hrs 2E-12 within < 24 hrs.		

Performance - Holdover (GPS or External input are not available)		
<b>Time (1PPS)</b>	<b>Drift</b>	≤ 1µs /24 hours (Typical)
<b>Frequency (10MHz)</b>		≤ 5E-11 /month

## SPECIFICATIONS (continue)

All specs are at room temperature, quiescent conditions, sea level ambient unless otherwise specified.

### Power Supply

<b>Input Voltage</b>	110 / 220VAC, 22-32 VDC (opt).
<b>Power</b>	<14 Watt @ 25°C (steady-state)

### Industrial GPS Receiver

<b>Tracking</b>	L1 frequency (1575 MHz), C/A code 12 parallel tracking channels
<b>Position</b>	Lat., long., alt.
<b>Position Accuracy</b>	6m CEP (50%) w/o SA
<b>GPS Antenna DC Voltage</b>	5V
<b>Acquisition Time</b>	Warm start 45 second, Cold start < 50 second (worst case)

### Dimensions & Weight

<b>Dimensions</b>	19", 1U – See Mechanical ICD below. 282(depth) ( 347 with handles & connectors)
<b>weight</b>	< 4 kg

### Reliability, Maintainability, Testability

<b>MTBF</b>	> 100,000 hours @ 30°C, GF, MIL-HBK-217F
<b>BIT (Built In Test)</b>	On-line BIT – Automatic, Covers 90% of all failures

### Principles of Operation

The following block diagrams depict the operation of the AR74A. The unit includes Rubidium and accepts Input from internal GPS receiver, external 1PPS or external TOD (H.Q). All outputs are derived from the internal Rubidium Clock, which is phase locked to the selected input. Thus, the Rubidium follows the GPS on average. If GPS reception is lost for short or long periods of time the Rubidium continues to maintain accurate time and frequency without phase interruption.

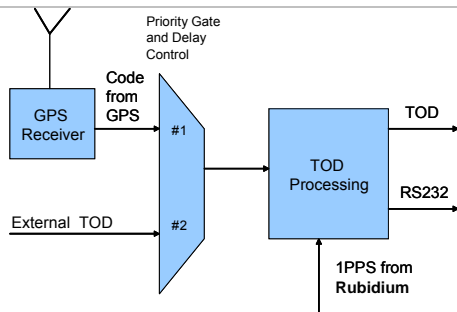

Data flow & Inputs Selection

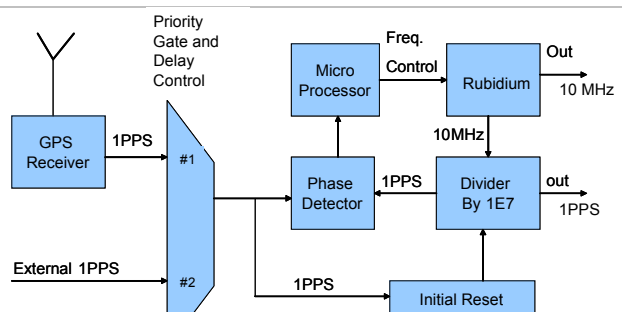

Rubidium-GPS D-PLL and Inputs

### Graphic User Interface (GUI) Software for PC (Opt.)

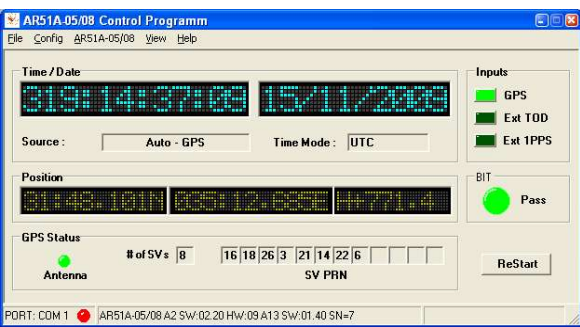

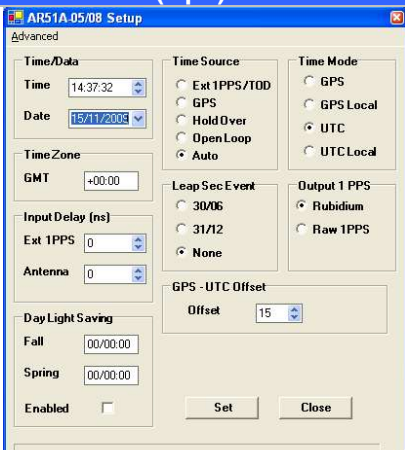

## SPECIFICATIONS *(continue)*

All specs are at room temperature, quiescent conditions, sea level ambient unless otherwise specified

### Mechanical ICD

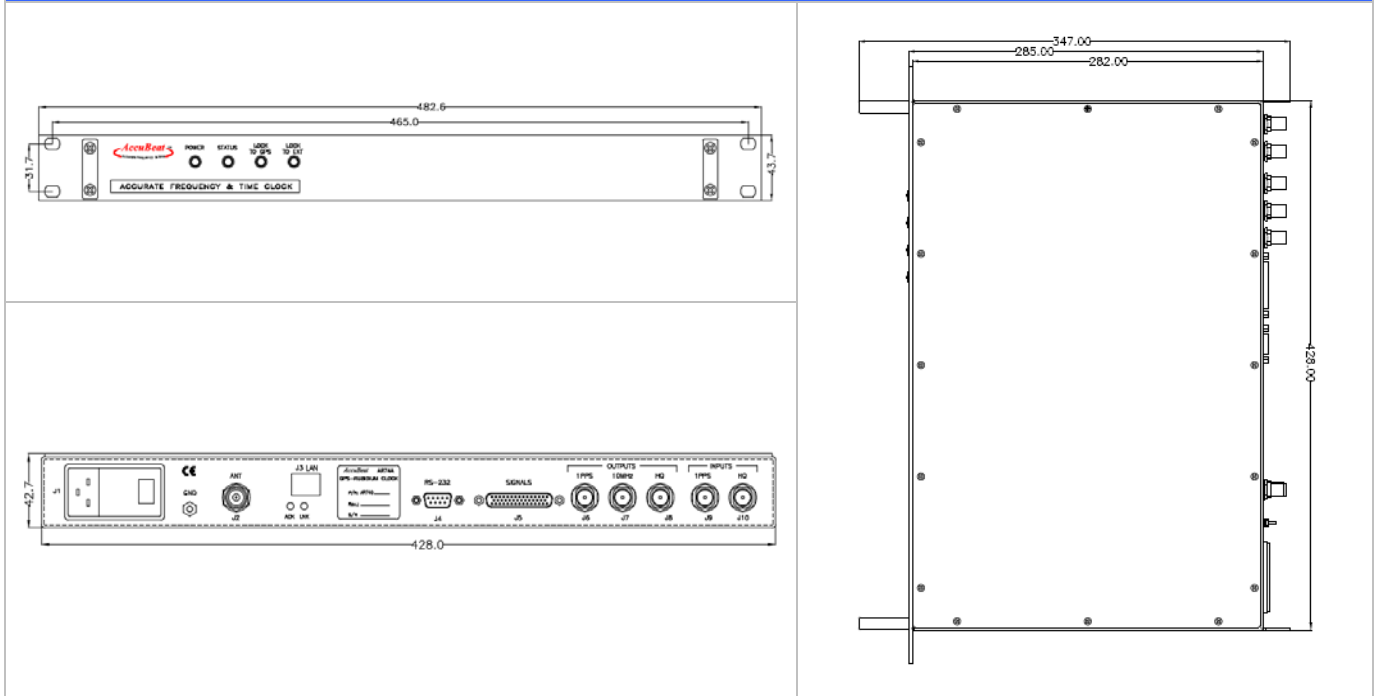

## HOW TO ORDER

OPTIONS		AccuBeat P/N	Note
Number	Description		
00	GPS Discipline Rubidium, 110/220VAC.	AR74A-00	

ACCESSORIES	AccuBeat P/N:
GPS Antenna 35 dB	EM30039
Antenna Cable RG-142 5m	AC50526
Antenna Cable RG-142 16m	AC50526-01
Antenna Cable RG-213 16m	AC50547
Antenna Cable LMR400 40m	AC50542
GUI Software for PC for Remote Control	SW50010

AccuBeat Ltd, 5 Ha'Marpeh St., Har Hotzvim, P.O.Box 45012, Jerusalem 91450, Israel  
 Tel: +972-2-5868330, Fax: +972-2-5868550, E-Mail: [marketing@accubeat.com](mailto:marketing@accubeat.com)  
<http://www.accubeat.com>